

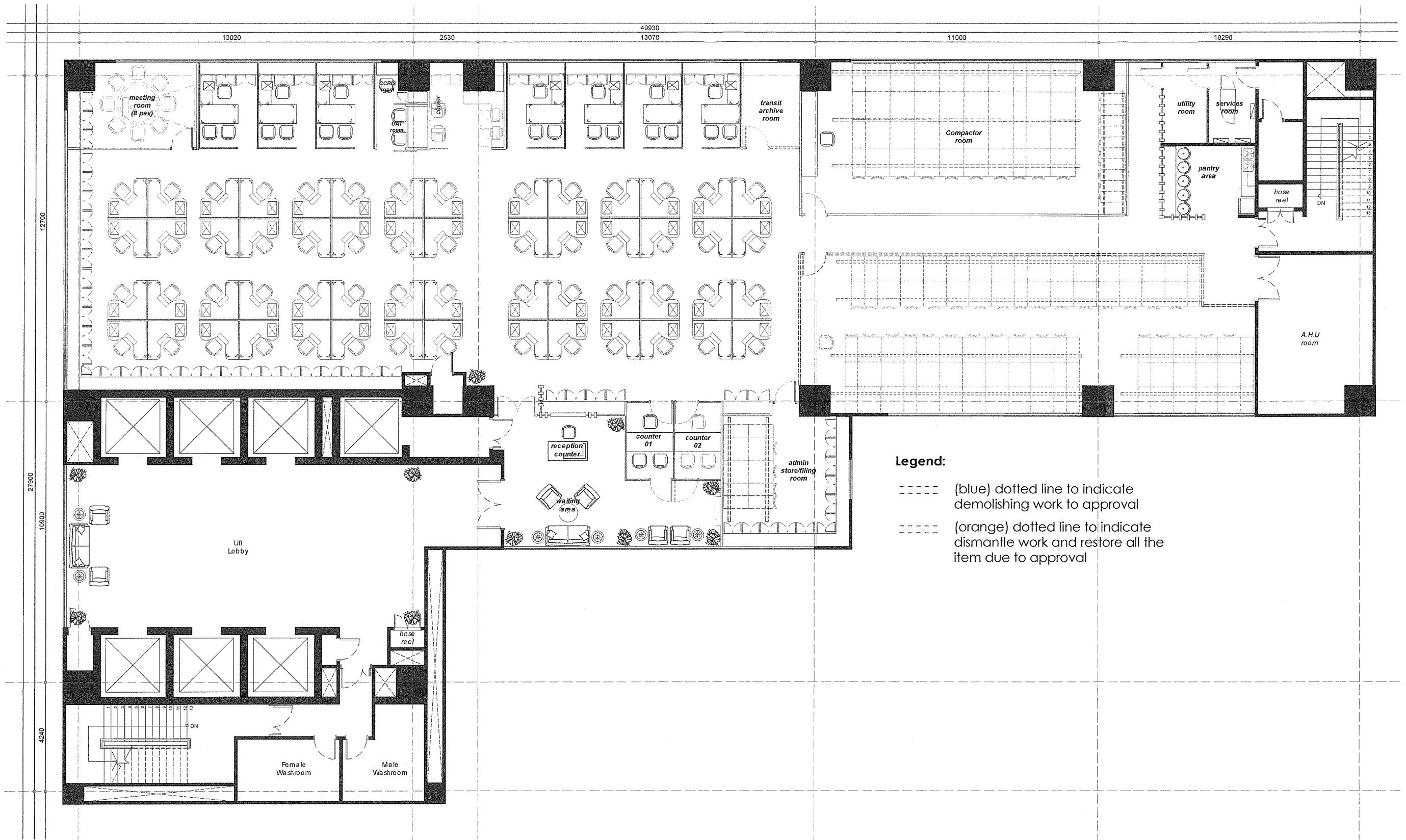

KERJA-KERJA PEMBAIKAN DAN  
UBAHSUAI KECIL RUANG PEJABAT  
JABATAN PEMULIHAN KREDIT DITINGKAT 5,  
BANGUNAN WISMA BSN, IBU PEJABAT,  
KUALA LUMPUR.



JABATAN PERKHIDMATAN AM  
& KESELAMATAN DALAMAN,  
TINGKAT 12, WISMA BSN,  
117 JALAN AMPANG,  
50450 KUALA LUMPUR.  
TEL : 03-2162 3222  
FAX : 03-2164 6367



**LAYOUT PLAN - 05TH FLOOR**  
SCALE 1:150 WISMA BSN

Projek	Disemak	Disahkan	Dipersetujui	Diluluskan	Maklumat Lukisan	
					Tajuk Lukisan	EXISTING LAYOUT PLAN-05TH FLOOR
 <p><b>BAHAGIAN PEMBANGUNAN DAN PENGURUSAN FASILITI</b> JABATAN PENTADBIRAN AM &amp; KESELAMATAN</p>	<p>CADANGAN KERJA-KERJA PEMBAIKAN DAN UBAHSUAI KECIL RUANG PEJABAT DI JABATAN PEMULIHAN KREDIT IBU PEJABAT, KUALA LUMPUR</p>	<p>Pengurus Jabatan Pemulihan Kredit</p>	<p>Naib Presiden/ Ketua Pemulihan Kredit</p>	<p>Ketua Pegawai Operasi BSN</p>	Dilukis oleh	MG
					Skala	1 : 150
					Tarikh	DEC 2020
					No. Lukisan	
					Pindaan	1   11   111   1V   V   V1
					Tarikh	

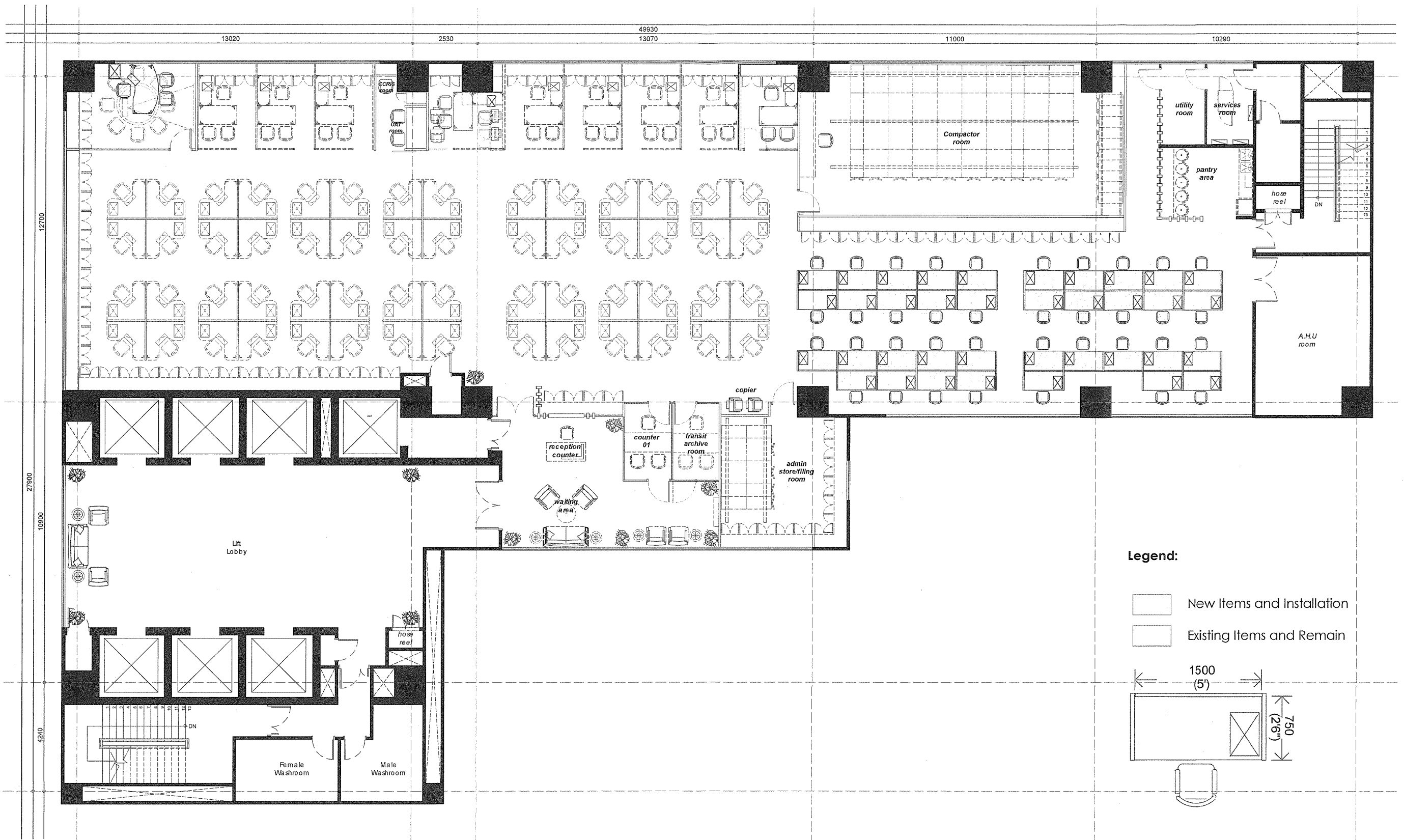

**LAYOUT PLAN - 05TH FLOOR**  
SCALE 1:150 WISMA BSN

# OPTION 1

Projek	Disemak	Disahkan	Dipersetujui	Diluluskan	Maklumat Lukisan	
					Tajuk Lukisan	Interior Layout Plan - 05th Floor
 BAHAGIAN PEMBANGUNAN DAN PENGURUSAN FASILITI JABATAN PENTADBIRAN AM & KESELAMATAN	CADANGAN KERJA-KERJA PEMBAIKAN DAN UBAHSUAI KECIL RUANG PEJABAT DI JABATAN PEMULIHAN KREDIT IBU PEJABAT, KUALA LUMPUR  <b>TINGKAT : 05</b>	_____  Pengurus Jabatan Pemulihan Kredit  Tarikh : _____	_____  Naib Presiden/ Ketua Pemulihan Kredit  Tarikh : _____	_____  Ketua Pegawai Operasi BSN  Tarikh : _____	Tajuk Lukisan	INTERIOR LAYOUT PLAN - 05TH FLOOR
					Dilukis oleh	MG
					Skala	1 : 150
					Tarikh	SEPT 2021
					No. Lukisan	
					Pindaan	1 11 111 1V V V1
					Tarikh	

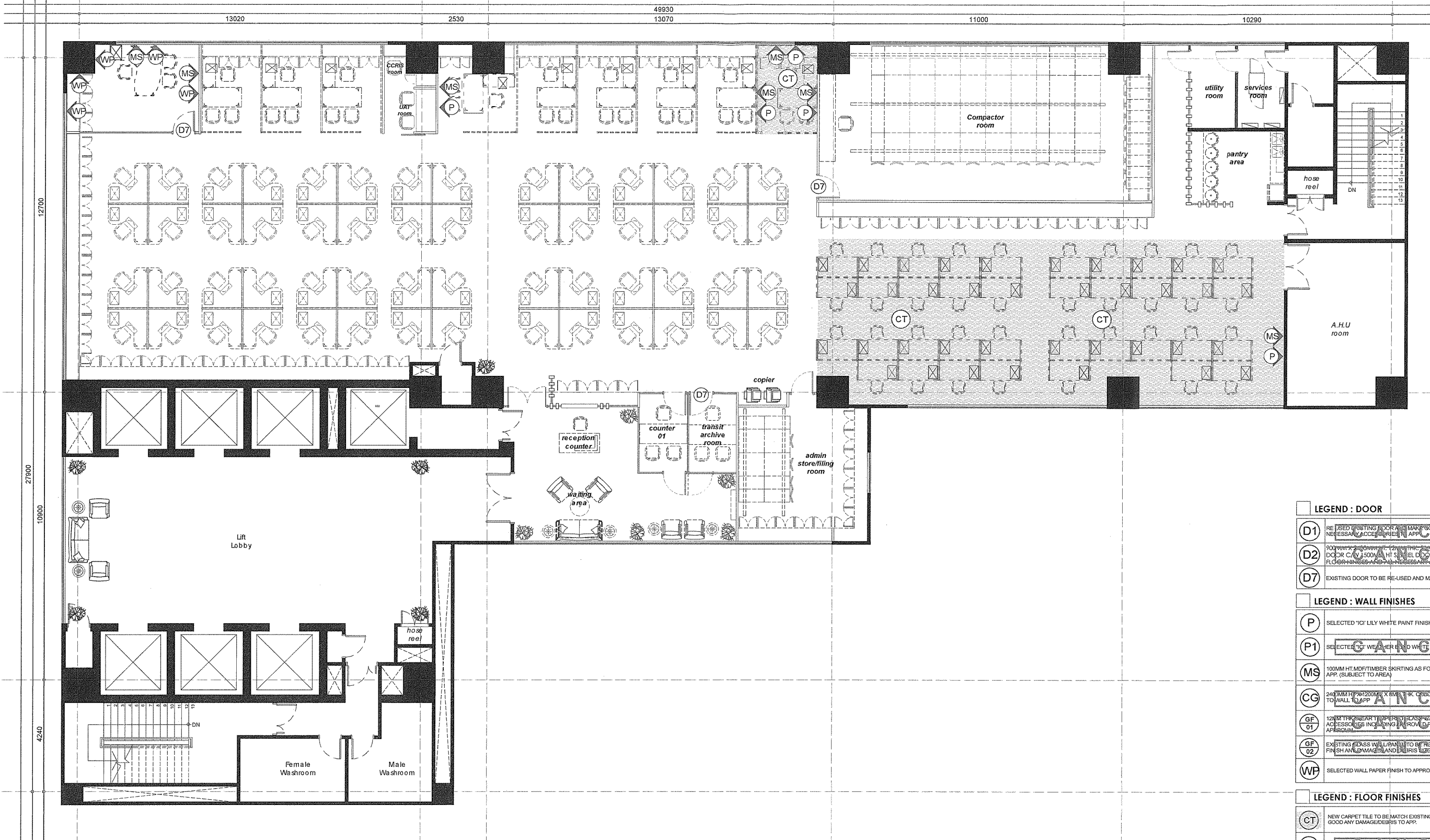

**LAYOUT PLAN - 05TH FLOOR**  
SCALE 1:150 WISMA BSN

LEGEND : DOOR	
D1	RE-USE EXISTING DOOR AND MAKE GOOD ANY DAMAGES IF NECESSARY ACCESSORIES TO APP.
D2	100MM HT. MDF/1200MM X 6MM THK. CLEAR TEMPERED GLASS DOOR C/W 500MM HT. STAINLESS STEEL DOOR HANDLE LOCKSET AND FLOOR FINISHES AND ALL NECESSARY AS PER SPEC.
D7	EXISTING DOOR TO BE RE-USED AND MAKE GOOD FINISH TO APP.
LEGEND : WALL FINISHES	
P	SELECTED 'ICI' LILY WHITE PAINT FINISH TO APP.
P1	SELECTED 'ICI' WEATHER BOND WHITE PAINT FINISH TO APP.
MS	100MM HT. MDF/TIMBER SKIRTING AS FOLLOW FLOOR FINISH TO APP. (SUBJECT TO AREA)
CG	240MM HT. 1200MM X 6MM THK. CLEAR TEMPERED GLASS PANEL FIXED TO WALL TO APP.
GF 01	12MM THK. CLEAR TEMPERED GLASS WALL AND ALL NECESSARY ACCESSORIES INCLUDING IN-ROOM FROSTED FILLS/TICKER TO APPROVAL.
GF 02	EXISTING GLASS WALL PARTS TO BE REMAIN AND MAKE GOOD FINISH AND DAMAGE AND REPAIRS IF NECESSARY TO APP.
WP	SELECTED WALL PAPER FINISH TO APPROVAL.
LEGEND : FLOOR FINISHES	
CT	NEW CARPET TILE TO BE MATCH EXISTING CARPET AND MAKE GOOD ANY DAMAGED DEBRIS TO APP.
HT	EXISTING HOMOGENEOUS TILE TO BE REMAIN AND MAKE GOOD OR REPLACE ANY DAMAGED DEBRIS TO APP.
RF	800MM X 800MM SELECTED FINE FLOOR C/W ALL NECESSARY ACCESSORIES TO APP.

Projek	Disemak	Disahkan	Dipersetujui	Diluluskan	Maklumat Lukisan
 <p><b>BSN</b> BAHAGIAN PEMBANGUNAN DAN PENGURUSAN FASILITI JABATAN PENTADBIRAN AM &amp; KESELAMATAN</p>	<p>CADANGAN KERJA-KERJA PEMBAIKAN DAN UBAHSUAI KECIL RUANG PEJABAT DI JABATAN PEMULIHAN KREDIT IBU PEJABAT, KUALA LUMPUR</p>	<p>Pengurus Jabatan Pemulihan Kredit</p>	<p>Naib Presiden/ Ketua Pemulihan Kredit</p>	<p>Ketua Pegawai Operasi BSN</p>	<p>Tajuk Lukisan <b>DOOR, WALL &amp; WALL FINISH LAYOUT PLAN</b></p>
					<p>Dilukis oleh <b>MG</b></p>
<p>TINGKAT : <b>05</b></p>	<p>Tarikh :</p>	<p>Tarikh :</p>	<p>Tarikh :</p>	<p>Tarikh :</p>	<p>Skala <b>1 : 150</b></p> <p>Tarikh <b>SEPT 2021</b></p> <p>No. Lukisan</p>
					<p>Pindaan <b>1 11 111 1V V V1</b></p>

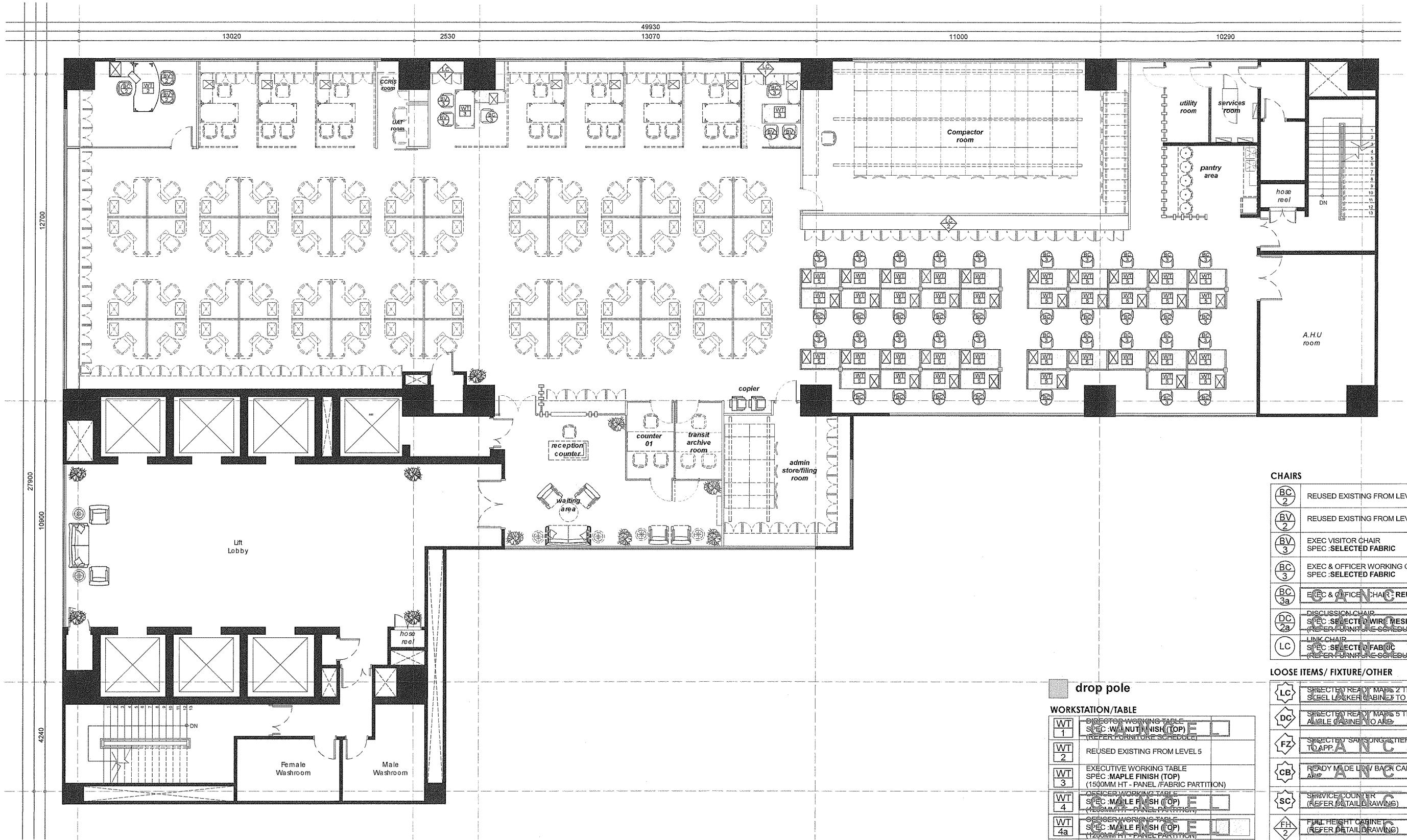

**LAYOUT PLAN - 05TH FLOOR**  
SCALE 1:150  
WISMA BSN

CHAIRS	
BC 2	REUSED EXISTING FROM LEVEL 5
BV 2	REUSED EXISTING FROM LEVEL 5
BV 3	EXEC VISITOR CHAIR SPEC :SELECTED FABRIC
BC 3	EXEC & OFFICER WORKING CHAIR SPEC :SELECTED FABRIC
BC 3a	EXEC & OFFICER CHAIR REUSED
DC 2a	DISCUSSION CHAIR SPEC :SELECTED WIRE MESH (REFER FURNITURE SCHEDULE)
LC	LINK CHAIR SPEC :SELECTED FABRIC (REFER FURNITURE SCHEDULE)

LOOSE ITEMS/ FIXTURE/OTHER	
LC	SPECIFIED READY MADE 2 TIER SHELVE/WORKER CABINET TO IEP
DC	SPECIFIED READY MADE 5 TIER DIXON ALUMI CABINET NO ANCH
FZ	SPECIFIED SANSUNG WATER BRIDGE TO APP
CB	READY MADE LOW BACK CABINET TO APP
SC	SERVICE COUNTER (REFER DETAIL DRAWING)
FH 2	FULL HEIGHT CABINET (REFER DETAIL DRAWING)
LC 1	LOW CABINET (REFER DETAIL DRAWING)
LC 2	LOW CABINET (REFER DETAIL DRAWING)

WORKSTATION/TABLE	
WT 1	DIRECTOR WORKING TABLE SPEC :MAPLE FINISH (TOP) (REFER FURNITURE SCHEDULE)
WT 2	REUSED EXISTING FROM LEVEL 5
WT 3	EXECUTIVE WORKING TABLE SPEC :MAPLE FINISH (TOP) (1500MM HT - PANEL /FABRIC PARTITION)
WT 4	OFFICER WORKING TABLE SPEC :MAPLE FINISH (TOP) (1200MM HT - PANEL PARTITION)
WT 4a	OFFICER WORKING TABLE SPEC :MAPLE FINISH (TOP) (1200MM HT - PANEL PARTITION)
WT 5	OFFICER WORKING TABLE SPEC :MAPLE FINISH (TOP) (1500MM LENGTH)
MT 1	MEETING TABLE SPEC :ZEBRANO FINISH (TOP) (1200MM X 2400MM)

Projek	Disemak	Disahkan	Diperseujui	Diluluskan	Maklumat Lukisan	
 <b>BAHAGIAN PEMBANGUNAN DAN PENGURUSAN FASILITI JABATAN PENTADBIRAN AM &amp; KESELAMATAN</b>	<b>CADANGAN KERJA-KERJA PEMBAIKAN DAN UBAHSUAI KECIL RUANG PEJABAT DI JABATAN PEMULIHAN KREDIT IBU PEJABAT, KUALA LUMPUR</b>	<b>Pengurus Jabatan Pemulihan Kredit</b>	<b>Naib Presiden/ Ketua Pemulihan Kredit</b>	<b>Ketua Pegawai Operasi BSN</b>	Tajuk Lukisan <b>WORKSTATION &amp; FURNITURE LAYOUT PLAN</b>	
					Dilulis oleh <b>MG</b>	
<b>TINGKAT : 05</b>	Tarikh :	Tarikh :	Tarikh :	Tarikh :	Skala <b>1 : 150</b>	
					Tarikh <b>SEPT 2021</b>	
					No. Lukisan	
Pindaan	1	11	111	1V	V	V1
Tarikh						



ZONE/AREA

**BACK OFFICE**

ITEM/DESCRIPTION

**WORKING TABLE**

CODE

**WT/3**

MEASUREMENT

IMAGE/SAMPLE

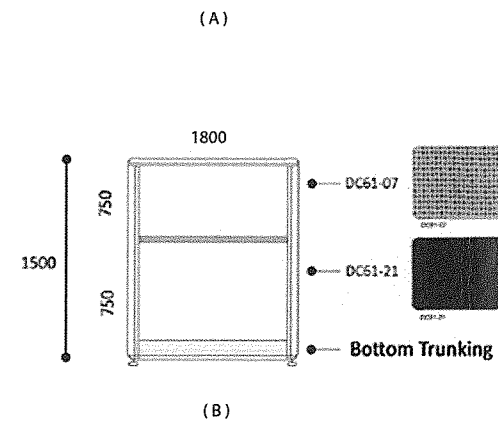
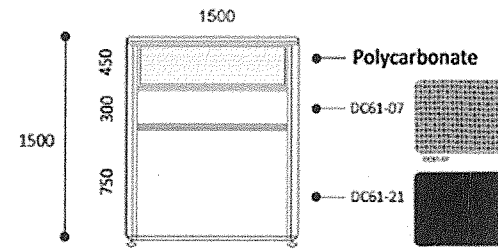
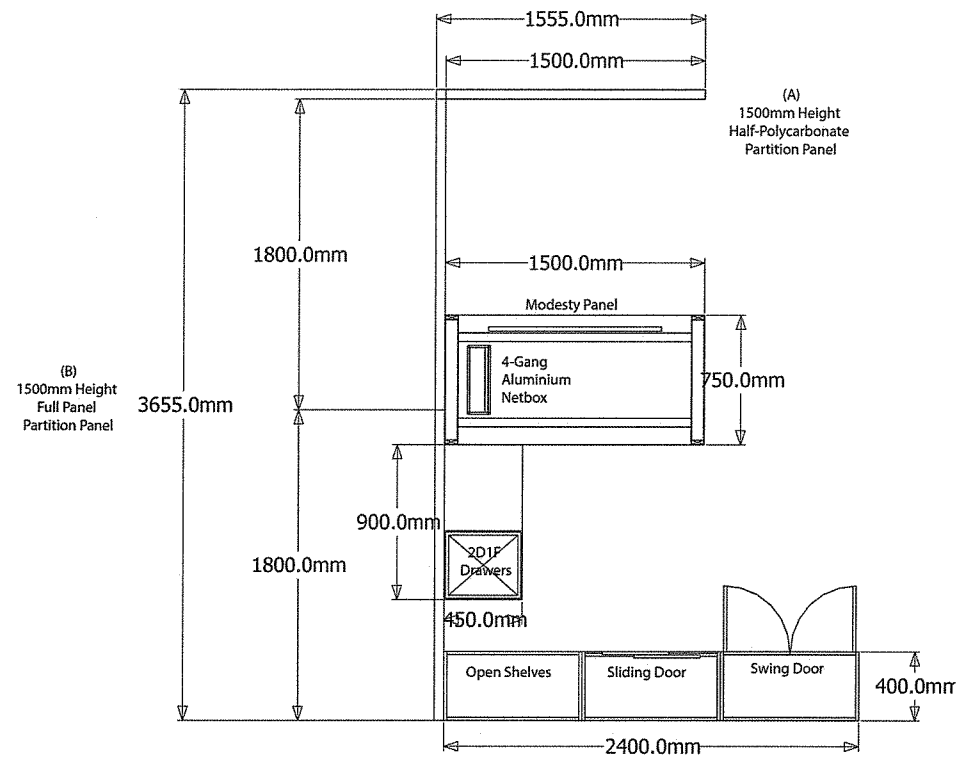

PANEL SYSTEM

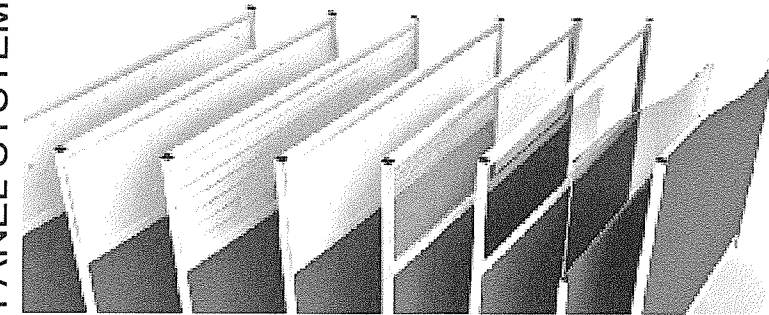

WORKSTATION

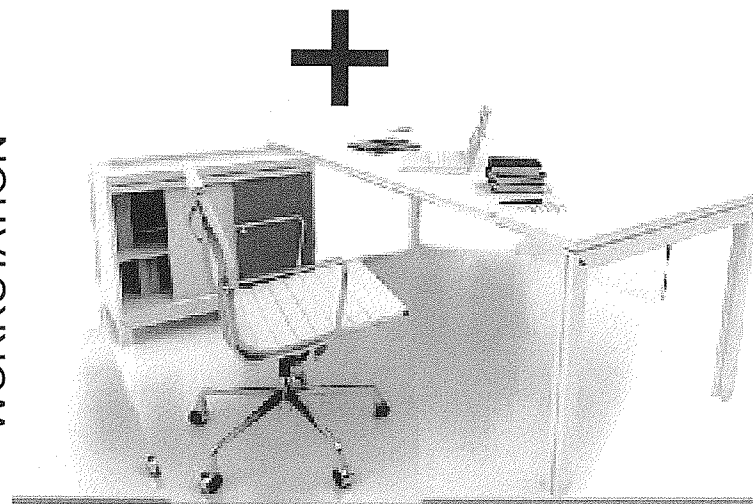

COLOR CODE/SAMPLE MATERIAL

TO DESIGNER'S ADVISE & APPROVAL.

QUANTITY

**REFER BILL OF QUANTITY (BQ)**

SPECIFICATION/TECHNICAL

Structure: 25mm / 18mm Melamine Laminated Board (MFC) with ABS/PVC Edging  
 + 1500 x 750 Main Worktop with 900 x 450 Side Return  
 + 4-Gang Aluminium Netbox  
 + 2D1F Drawers Pedestal  
 + XT Aluminium Frame Desking System  
 + Metal Perforated Modesty Panel  
 + Ultegra® X5 Series Silver Anodized Aluminium Frame Partition Panel  
 + Open / Sliding / Swing Door Back Cabinet  
 Size: (Table) 1500/750 x 1650/450 x 750H mm  
 (Back Cabinet) 2400 x 400 x 900H mm

LOCATION

**SECTION HEAD AREA**

	Projek	Disemak	Disahkan	Dipersejujui	Diluluskan	Maklumat Lukisan
<p>BAHAGIAN PEMBANGUNAN DAN PENGURUSAN FASILITI JABATAN PENTADBIRAN AM &amp; KESELAMATAN</p>	<p><b>CADANGAN KERJA-KERJA PEMBAIKAN DAN UBAHSUAI KECIL RUANG PEJABAT DI JABATAN PEMULIHAN KREDIT IBU PEJABAT, KUALA LUMPUR</b></p> <p><b>TINGKAT : 05</b></p>	Wakil Jabatan Pemulihan Kredit	Pengurus Jabatan Pemulihan Kredit	Naib Presiden Kanan/ Ketua Pemulihan Kredit	Ketua Pegawai Operasi BSN	Tajuk Lukisan: <b>WORKING TABLE TYPE WT3</b>
		Tarikh :	Tarikh :	Tarikh :	Tarikh :	Dilukis oleh: MG
						Skala: 1 : 150
						Tarikh: SEPT 2021
						No. Lukisan:
						Tarikh:
					Pindaan: 1 11 111 1V V V1	
					Tarikh:	





ZONE/AREA

ITEM/DESCRIPTION

CODE

BACK OFFICE

VISITOR CHAIR

BV/3

MEASUREMENT

IMAGE/SAMPLE

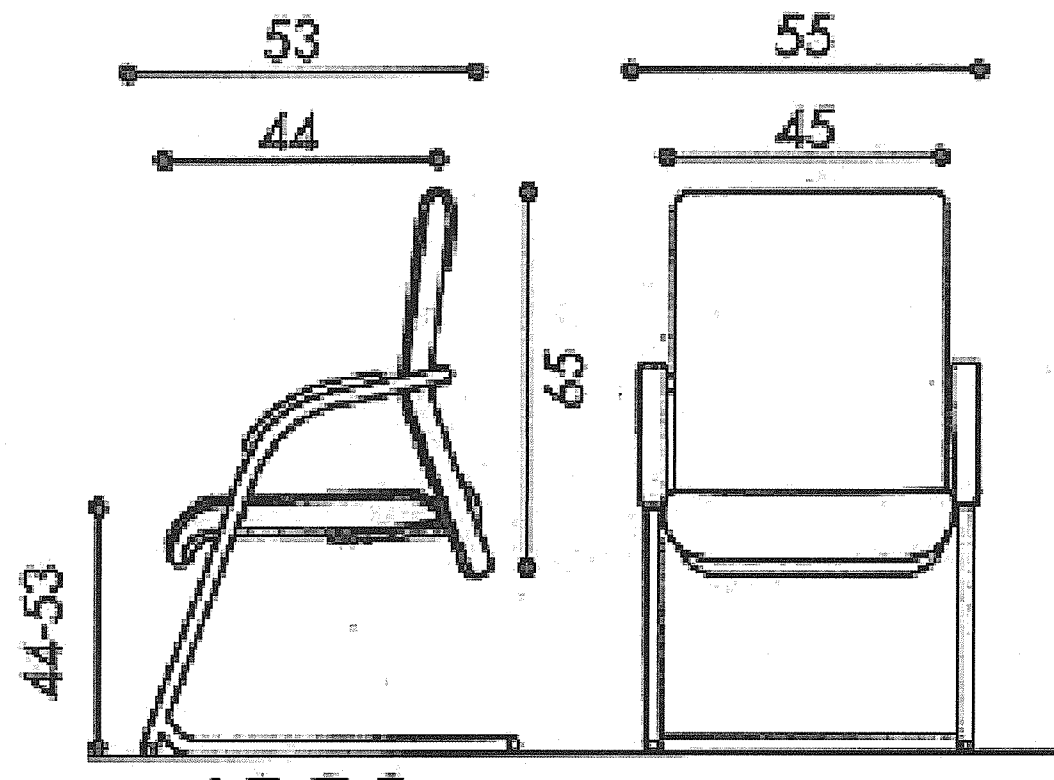

COLOR CODE/SAMPLE MATERIAL

QUANTITY



COLOUR AND FABRIC : TO BE SELECTED

REFER BILL OF QUANTITY (BQ)

SPECIFICATION

LOCATION

- CANTILEVER VISITOR CHAIR
- EPOXY WHITE PAINT FINISH WITH BLACK PU ARMREST TO APP..

\*READY MADE - TO BE DESIGNERS APPROVAL.

HEAD SECTION AREA

	Projek	Disemak	Disahkan	Dipersetujui	Diluluskan	Maklumat Lukisan
 BAHAGIAN PEMBANGUNAN DAN PENGURUSAN FASILITI JABATAN PENTADBIRAN AM & KESELAMATAN	CADANGAN KERJA-KERJA PEMBAIKAN DAN UBAHSUAI KECIL RUANG PEJABAT DI JABATAN PEMULIHAN KREDIT IBU PEJABAT, KUALA LUMPUR					Tajuk Lukisan VISITOR CHAIR TYPE BV3 Dilukis oleh MG Skala 1 : 150 Tarikh SEPT 2021 No. Lukisan Pindaan 1 11 111 1V V V1 Tarikh
	TINGKAT : 05	_____ Wakil Jabatan Pemulihan Kredit Tarikh :	_____ Pengurus Jabatan Pemulihan Kredit Tarikh :	_____ Naib Presiden Kanan/ Ketua Pemulihan Kredit Tarikh :	_____ Ketua Pegawai Operasi BSN Tarikh :	



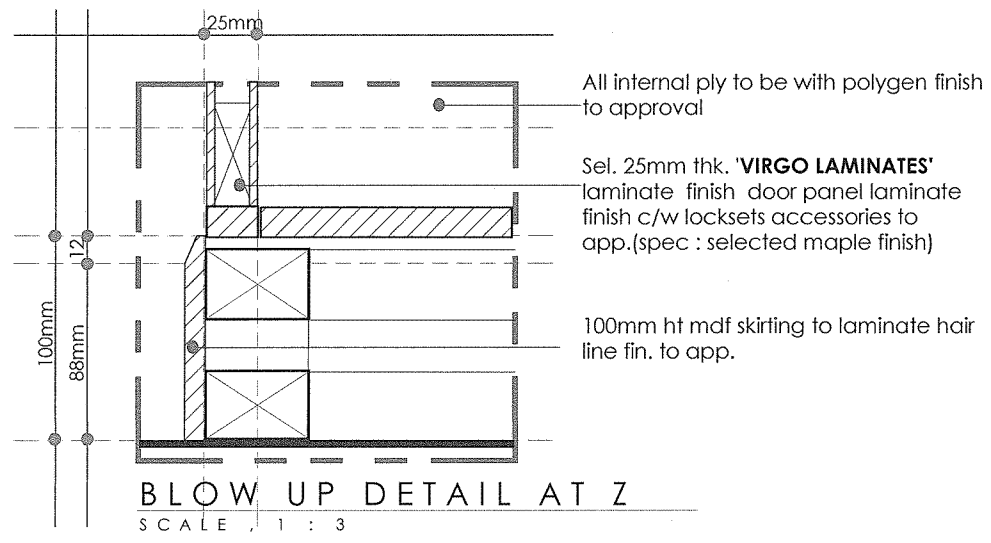
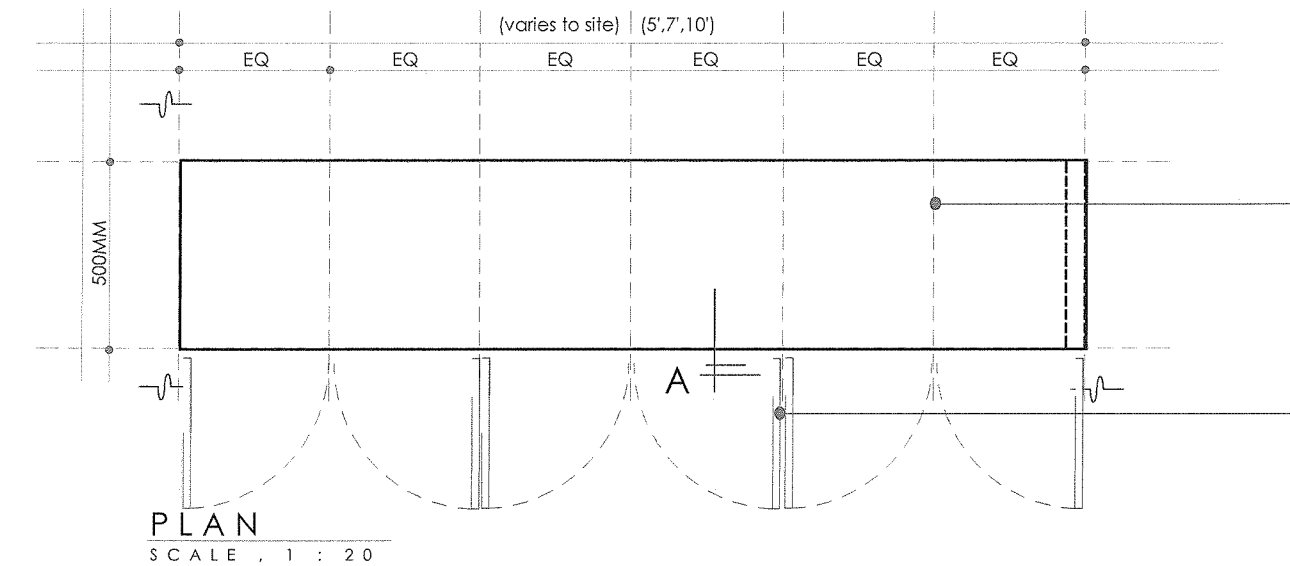
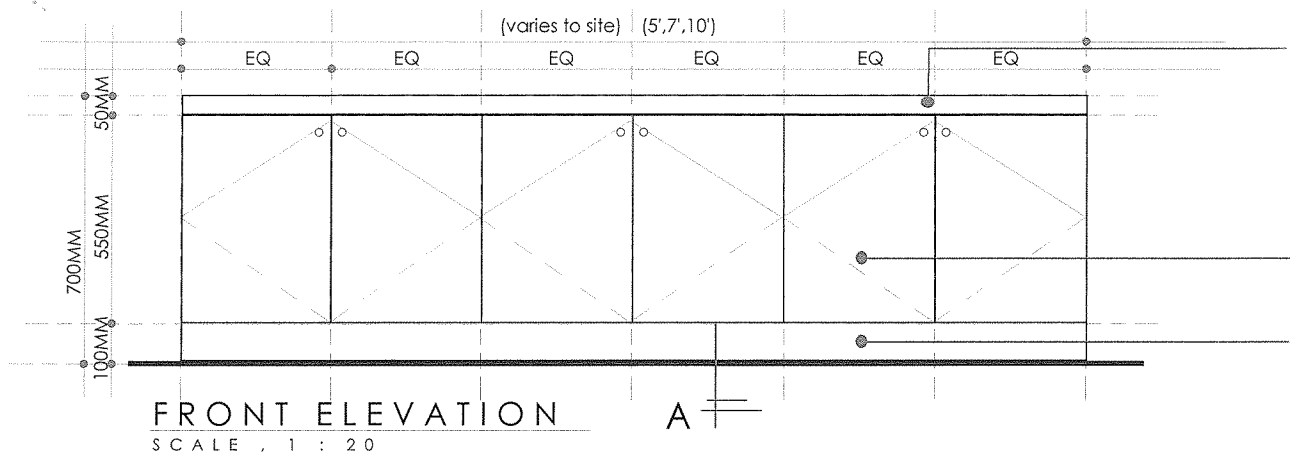

50mm thk. 'VIRGO LAMINATES' postform laminate top finish c/w bull nose edge to app.(spec : selected black laminate finish)

50mm thk. 'VIRGO LAMINATES' postform laminate top finish c/w bull nose edge to app.(spec : selected black laminate finish)

Sel. 25mm thk. 'VIRGO LAMINATES' laminate finish door panel laminate finish c/w locksets accessories to app.(spec : selected maple finish)  
100mm ht mdf skirting to laminate hair line fin. to app.

All internal ply to be with polygen finish to approval

Sel. 25mm thk. 'VIRGO LAMINATES' laminate finish door panel laminate finish c/w locksets accessories to app.(spec : selected maple finish)

50mm thk. 'VIRGO LAMINATES' postform laminate top finish c/w bull nose edge to app.(spec : selected black laminate finish)

100mm ht mdf skirting to laminate hair line fin. to app.

Sel. 25mm thk. 'VIRGO LAMINATES' laminate finish door panel laminate finish c/w locksets accessories to app.(spec : selected maple finish)

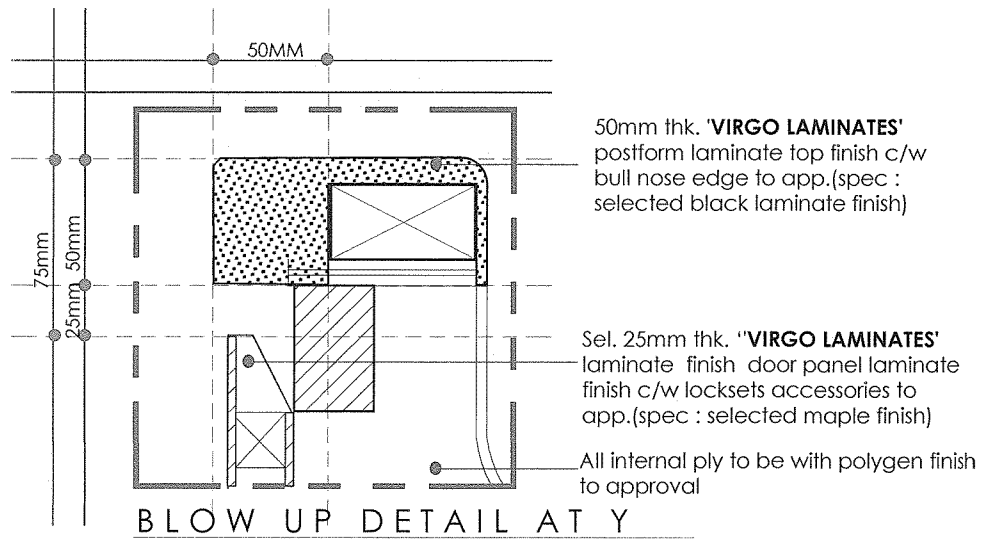
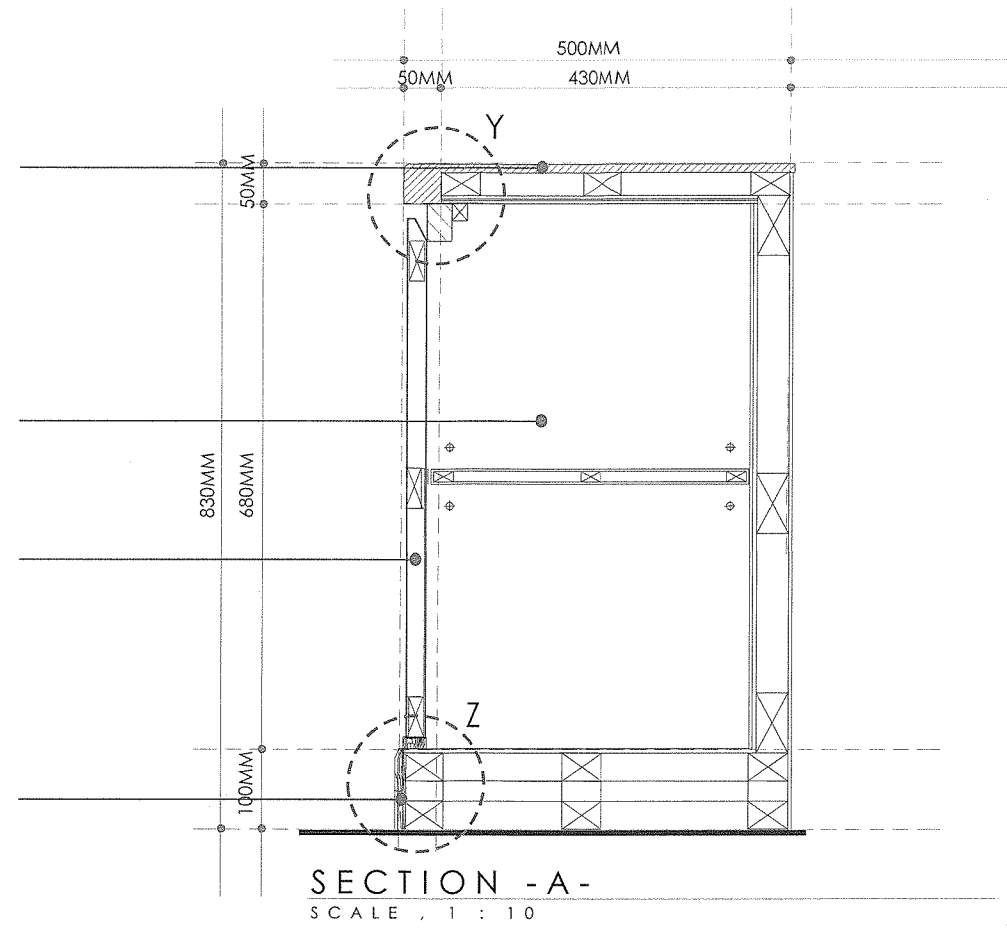

TYPICAL LOW CABINET (5',7',10' LOOSE) DETAIL - LC/1

Projek	Disemak	Disahkan	Dipersetujui	Diluluskan	Maklumat Lukisan		
					Tajuk Lukisan	LOW CABINET DETAIL TYPE : LC/1	
 <p>BAHAGIAN PEMBANGUNAN DAN PENGURUSAN FASILITI JABATAN PENTADBIRAN AM &amp; KESELAMATAN</p>	<p>CADANGAN KERJA-KERJA PEMBAIKAN DAN UBAHSUAI KECIL RUANG PEJABAT DI JABATAN PEMULIHAN KREDIT IBU PEJABAT, KUALA LUMPUR</p>	<p>Wakil Jabatan Pemulihan Kredit</p>	<p>Pengurus Jabatan Pemulihan Kredit</p>	<p>Naib Presiden Kanan/ Ketua Pemulihan Kredit</p>	<p>Ketua Pegawai Kewangan BSN</p>	Dilukis oleh	MG
						Skala	1 : 150
						Tarikh	SEPT 2021
						No. Lukisan	
						Pindaan	1 11 111 1V V V1
						Tarikh	

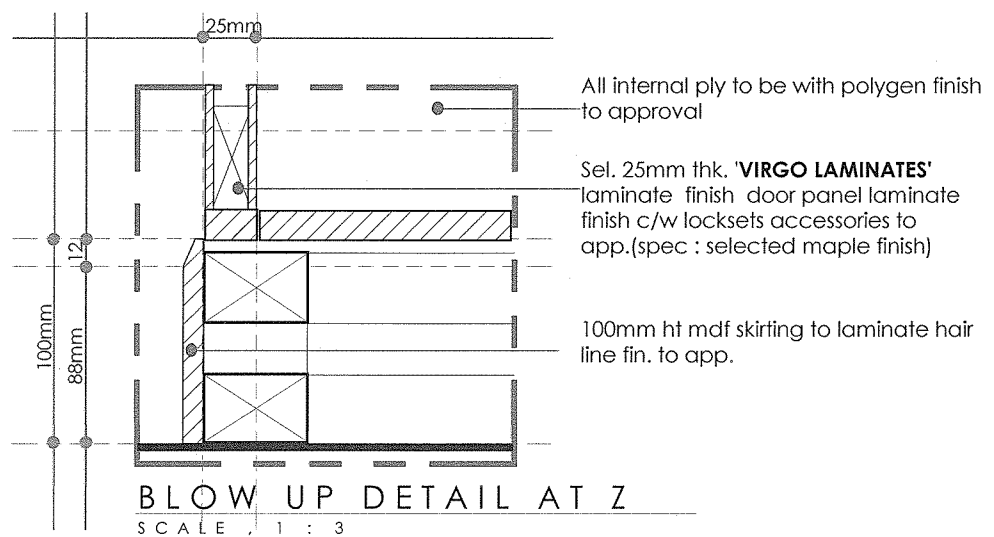
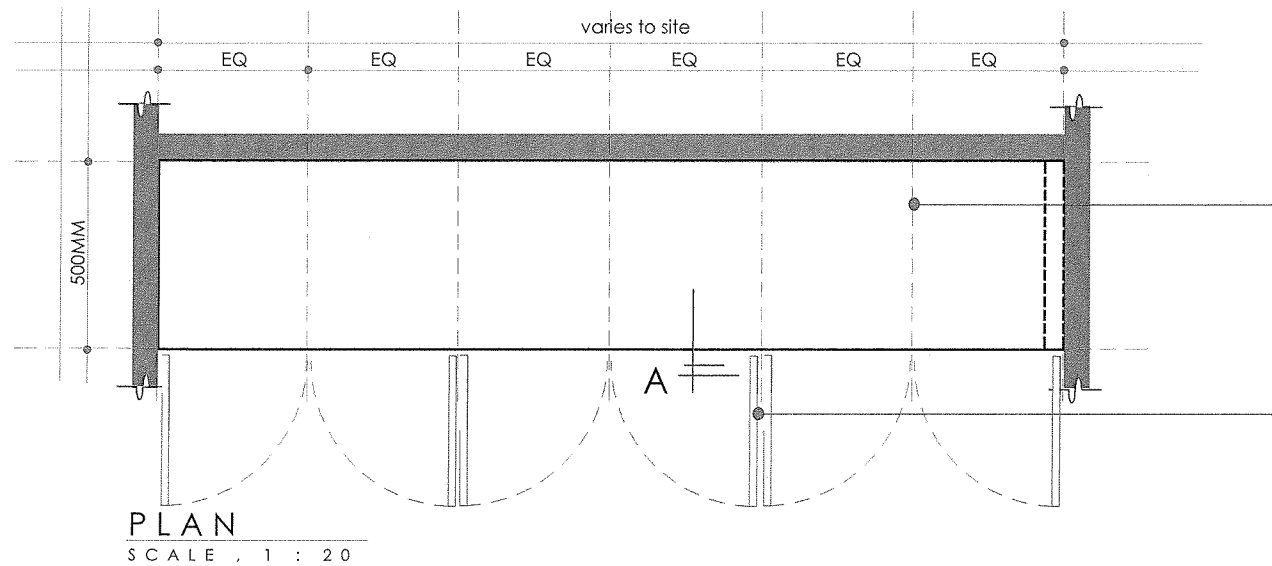
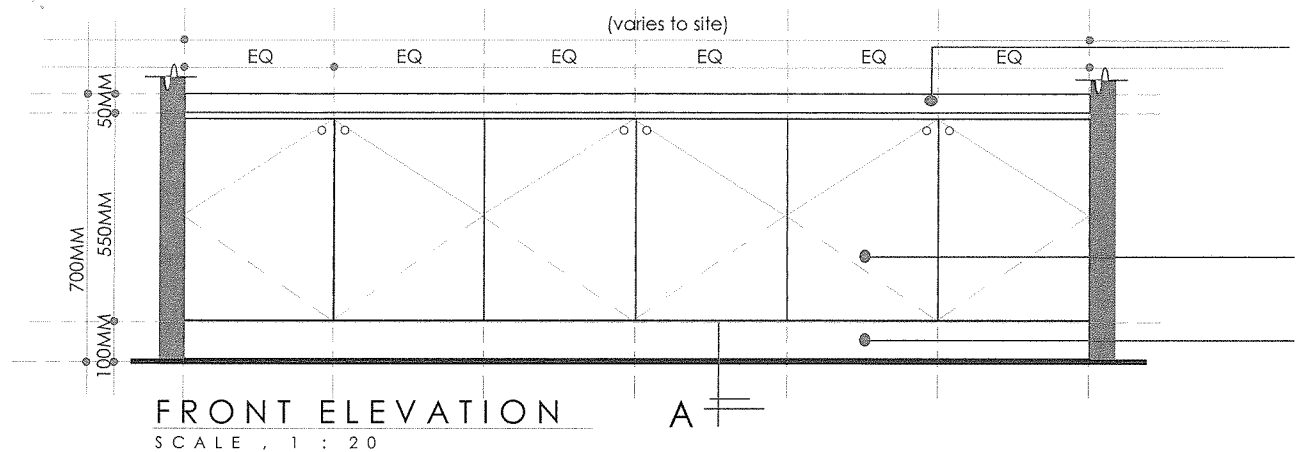

50mm thk. 'VIRGO LAMINATES' postform laminate top finish c/w bull nose edge to app.(spec : selected black laminate finish)

50mm thk. 'VIRGO LAMINATES' postform laminate top finish c/w bull nose edge to app.(spec : selected black laminate finish)

Sel. 25mm thk. 'VIRGO LAMINATES' laminate finish door panel laminate finish c/w locksets accessories to app.(spec : selected maple finish)  
100mm ht mdf skirting to laminate hair line fin. to app.

All internal ply to be with polygen finish to approval

Sel. 25mm thk. 'VIRGO LAMINATES' laminate finish door panel laminate finish c/w locksets accessories to app.(spec : selected maple finish)

50mm thk. 'VIRGO LAMINATES' postform laminate top finish c/w bull nose edge to app.(spec : selected black laminate finish)

100mm ht mdf skirting to laminate hair line fin. to app.

Sel. 25mm thk. 'VIRGO LAMINATES' laminate finish door panel laminate finish c/w locksets accessories to app.(spec : selected maple finish)

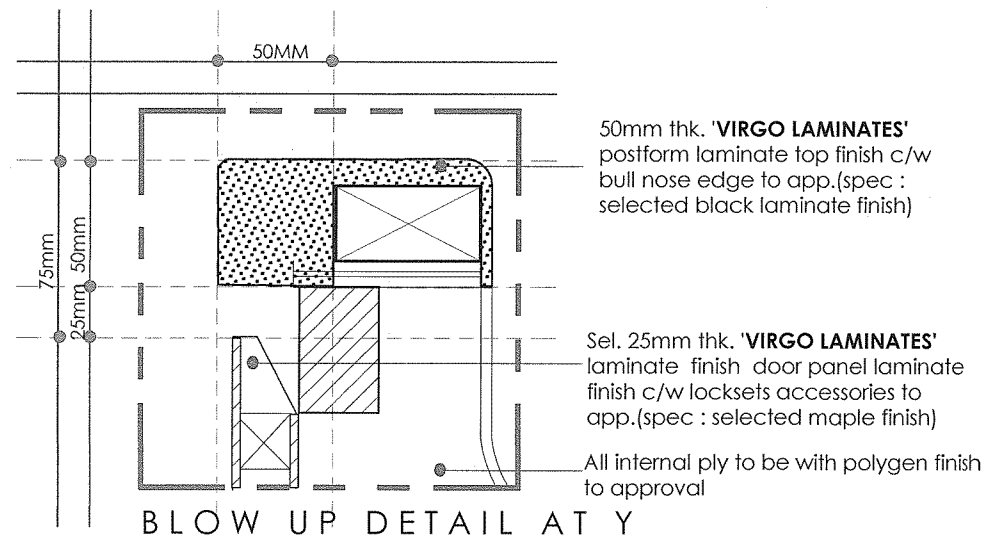
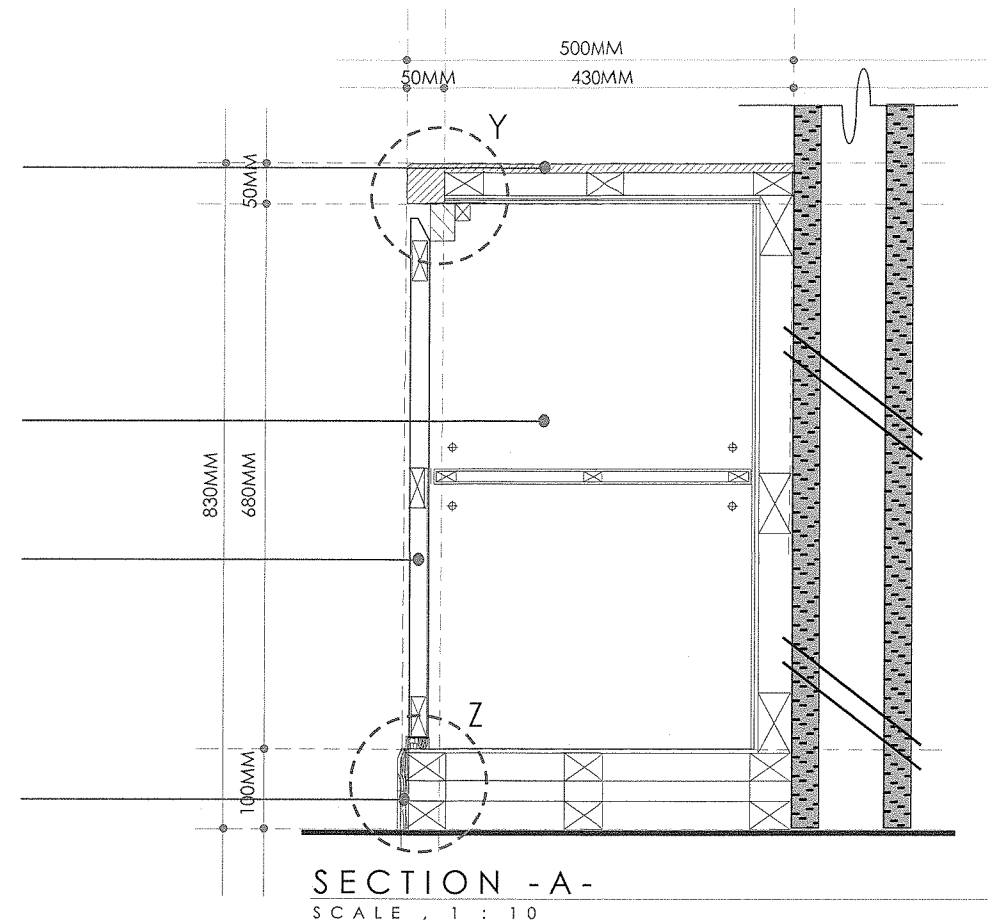

TYPICAL LOW CABINET (FIXED) DETAIL - LC/02

Projek	Disema k	Disa hka n	Diperse tuju i	Diluluska n	Makluma t Lukisa n		
					Tajuk Lukisa n	LOW CABINET DETAIL TYPE : LC/1	
 <p>BAHAGIAN PEMBANGUNAN DAN PENGURUSAN FASILITI JABATAN PENTADBIRAN AM &amp; KESELAMATAN</p>	<p>CADANGAN KERJA-KERJA PEMBAIKAN DAN UBAHSUAI KECIL RUANG PEJABAT DI JABATAN PEMULIHAN KREDIT IBU PEJABAT, KUALA LUMPUR</p>	<p>Wakil Jabatan Pemulihan Kredit</p>	<p>Pengurus Jabatan Pemulihan Kredit</p>	<p>Naib Presiden Kanan/ Ketua Pemulihan Kredit</p>	<p>Ketua Pegawai Operasi BSN</p>	Dilukis oleh	MG
						Skala	1 : 150
						Tarikh	SEPT 2021
						No. Lukisa n	
						Pindaan	1 11 111 1V V V1
						Tarikh	

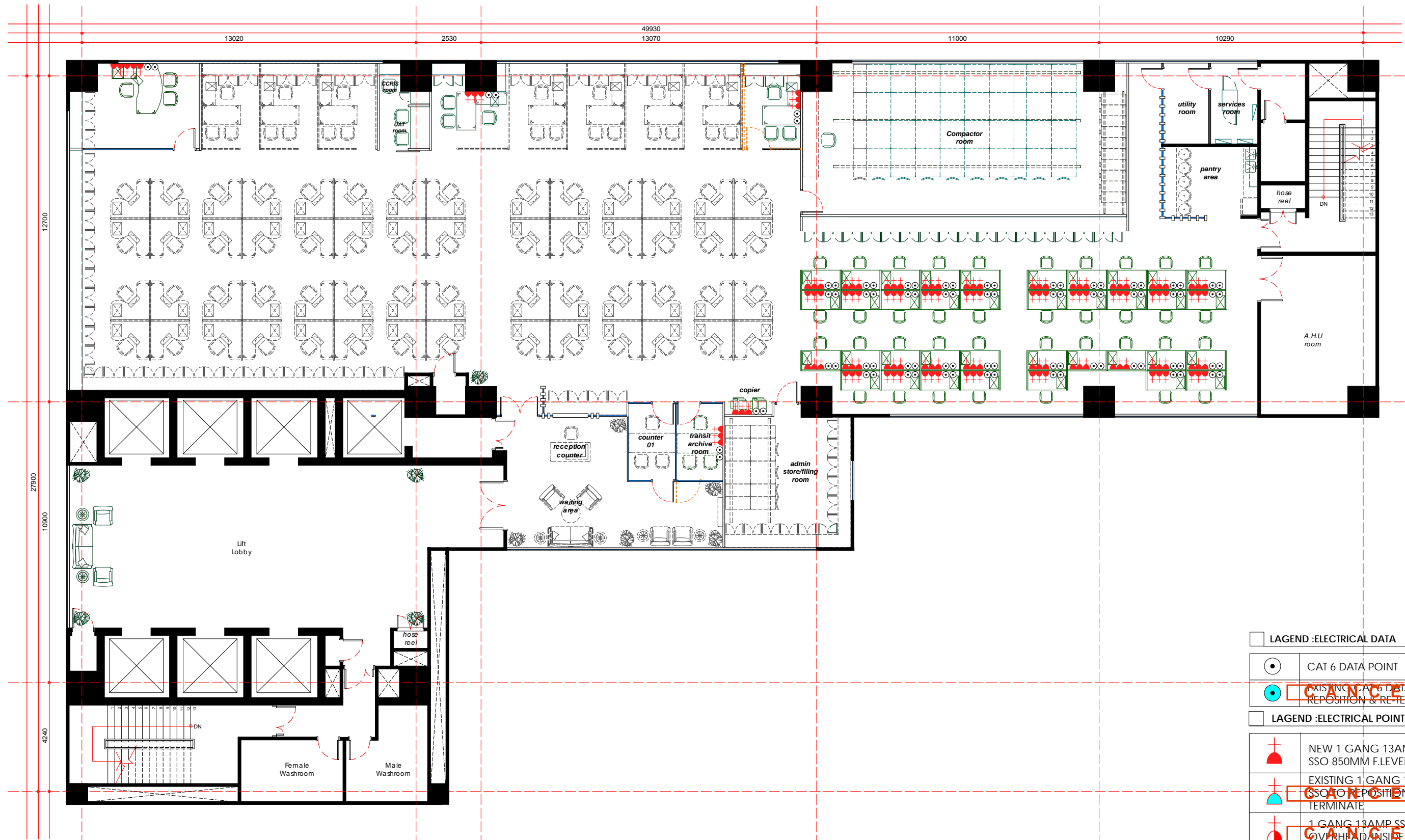

**ELECTRICAL POINT LAYOUT PLAN - 05TH FLOOR**  
 SCALE 1:150  
**WISMA BSN**

LEGEND :ELECTRICAL DATA	
	CAT 6 DATA POINT
	EXISTING 1 GANG 13AMP SSO DATA POINT TO REPOSITION & RE-TERMINATE
LEGEND :ELECTRICAL POINT	
	NEW 1 GANG 13AMP (N/E) SSO 850MM F.LEVEL
	EXISTING 1 GANG 13AMP (N/E) SSO TO REPOSITION & RE-TERMINATE
	1 GANG 13AMP SSO AT OVERHEAD IN S/C CEILING
	1 GANG 13AMP SSO 300MM F.LEVEL

<p>BAHAGIAN PEMBANGUNAN DAN PENGURUSAN FASILITI          JABATAN PENTADBIRAN AM &amp; KESELAMATAN</p>	<b>Projek</b> CADANGAN KERJA-KERJA PEMBAIKAN DAN UBAHSUAI KECIL RUANG PEJABAT DI JABATAN PEMULIHAN KREDIT IBU PEJABAT, KUALA LUMPUR	<b>Disemak</b>   Tarikh :	<b>Disahkan</b>  Pengurus Jabatan Pemulihan Kredit Tarikh :	<b>Dipersetujui</b>  Naib Presiden/ Ketua Pemulihan Kredit Tarikh :	<b>Diluluskan</b>  Ketua Pegawai Operasi BSN Tarikh :	<b>Maklumat Lukisan</b> Tajuk Lukisan : <b>ELECTRICAL POINT LAYOUT PLAN</b> Dilukis oleh : MG Skala : 1 : 150 Tarikh : SEPT 2021 No. Lukisan : Pindaan : 1 11 111 1V V V1 Tarikh :
	<b>TINGKAT : 05</b>					